

## INSTALLATION AND OPERATING INSTRUCTIONS FOR THERMOSTATIC MIXING VALVES COMPLYING WITH N.H.S. ESTATES MODEL ENGINEERING SPECIFICATION D08

THE VALVE COVERED IN THIS BOOKLET HAS BEEN TESTED AND APPROVED  
TO N.H.S. ESTATES MODEL ENGINEERING SPECIFICATION D08

IT MAY PERFORM SATISFACTORILY OUTSIDE THE LIMITS SPECIFIED HOWEVER  
IT WILL NOT BE COVERED BY THE TMV2 AND TMV3 SCHEME

### SF1337XX

15mm Thermostatic Mixing Valve

HP-S	High Pressure Shower
HP-W	High Pressure Wash Basin
LP-S	Low Pressure Shower
LP-W	Low Pressure Wash Basin
HP-T44	High Pressure Bath Fill With Temperature Up To 44°C

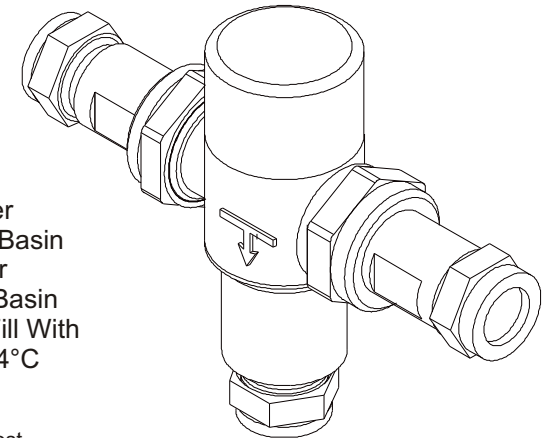

TMV2 approval information available on request  
TMV3 approval information available on request  
WRAS approval information available on request

## TEMPERATURE STABILISED THERMOSTATIC MIXING VALVE

Twyford Bathrooms  
Lawton Road  
Alsager  
Stoke-on-Trent  
ST7 2DF  
UK

**UK Technical Helpline**  
Telephone 0870 840 0437  
Fax 0870 840 0438  
Twyford.technical@twyfordbathrooms.com

Form No. 800527/A

## INTRODUCTION

It has been recognised that users of hot water in care establishments are at risk from scalding. This risk has been reduced by the use of thermostatic mixing valves. In order to assure the performance of thermostatic mixing valves N.H.S. Estates Model Engineering Specification DO8 was written. The valve listed in the following pages has been tested and approved to this standard by a third party as part of the Build Cert scheme for use within their designated applications.

This Thermostatic mixing valve has also been tested to the TMV2 scheme which works to the tests found in the BS EN 1287 (LP) and BS EN 1111 (HP)

The following abbreviated designation codes are used throughout this booklet. Detailed descriptions are given below:-

HP	High pressure
LP	Low pressure
S	Shower
B	Bidet
W	Washbasin
T44	Bath with fill temperature of 44°C max
T46	Bath with fill temperature of 46°C max
BE	Bidet with economy flow rate
SE	Shower with economy flow rate
WE	Washbasin with economy flow rate

**SF1337XX** APPROVED FOR USE IN THE FOLLOWING DESIGNATIONS

CODE	OPERATING PRESSURE	APPLICATION
HP-S	HIGH PRESSURE	SHOWER
HP-W	HIGH PRESSURE	WASH BASIN
LP-S	LOW PRESSURE	SHOWER
LP-W	LOW PRESSURE	WASH BASIN
HP-T44	HIGH PRESSURE	BATH FILL WITH TEMPERATURE UP TO 44°C

For full installation instructions and method of temperature adjustment see General Assembly and Servicing Guide.

## INSTALLATION RECOMMENDATIONS

The following general recommendations should be observed.

- 1) Always install isolating valves to facilitate servicing.
- 2) Always flush both supply pipes fully before connecting mixing valve to ensure no pipe debris Enters the inlets. Always fit filters provided.
- 3) All installations must comply with current local water company regulations.

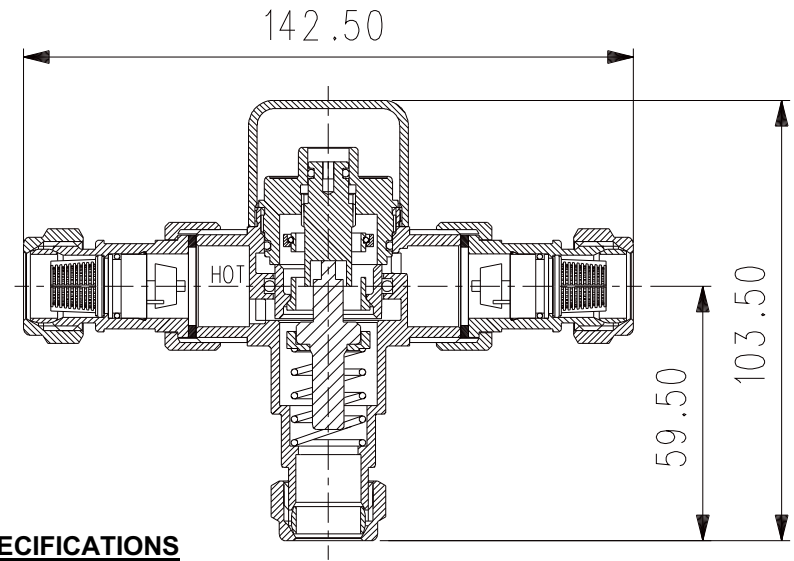

## CONNECTIONS SPECIFICATIONS

INLETS	15mm Compression
OUTLET	15mm Compression

## SPECIFICATIONS

Minimum pressure drop through fitting for correct mixing	0.1 bar (1 Metre head)
Maximum pressure drop through fitting for correct mixing	5.0 bar (50 Metre head)
Maximum static pressure to be applied to fitting	10.0 bar (100 Metre head)
Maximum pressure loss ratio	20:1 either supply
Temperature stability with normal variation of supply temperatures and pressures	± 2°C from set temperature
Factory set standard blend temperature	43°C
Maximum hot supply temperature	80°C

The sensitive wax capsule will shut down the operation of the valve if either the hot or cold water supply fails, provided a minimum differential of 10°C exists between the mixed water temperature and the remaining supply.

## PERFORMANCE

PRESSURE DROP (BARS)	0.1	0.2	0.4	0.6	0.8	1	1.5	2	3	4	5
FLOW RATE (LITRES/MIN)	5.9	9.8	14.7	18.2	21.3	23.8	30.5	35.0	42.5	49.5	55.2

Flow rates are open outlet with equal pressure drops, fitted with Check valves and Filters as supplied.

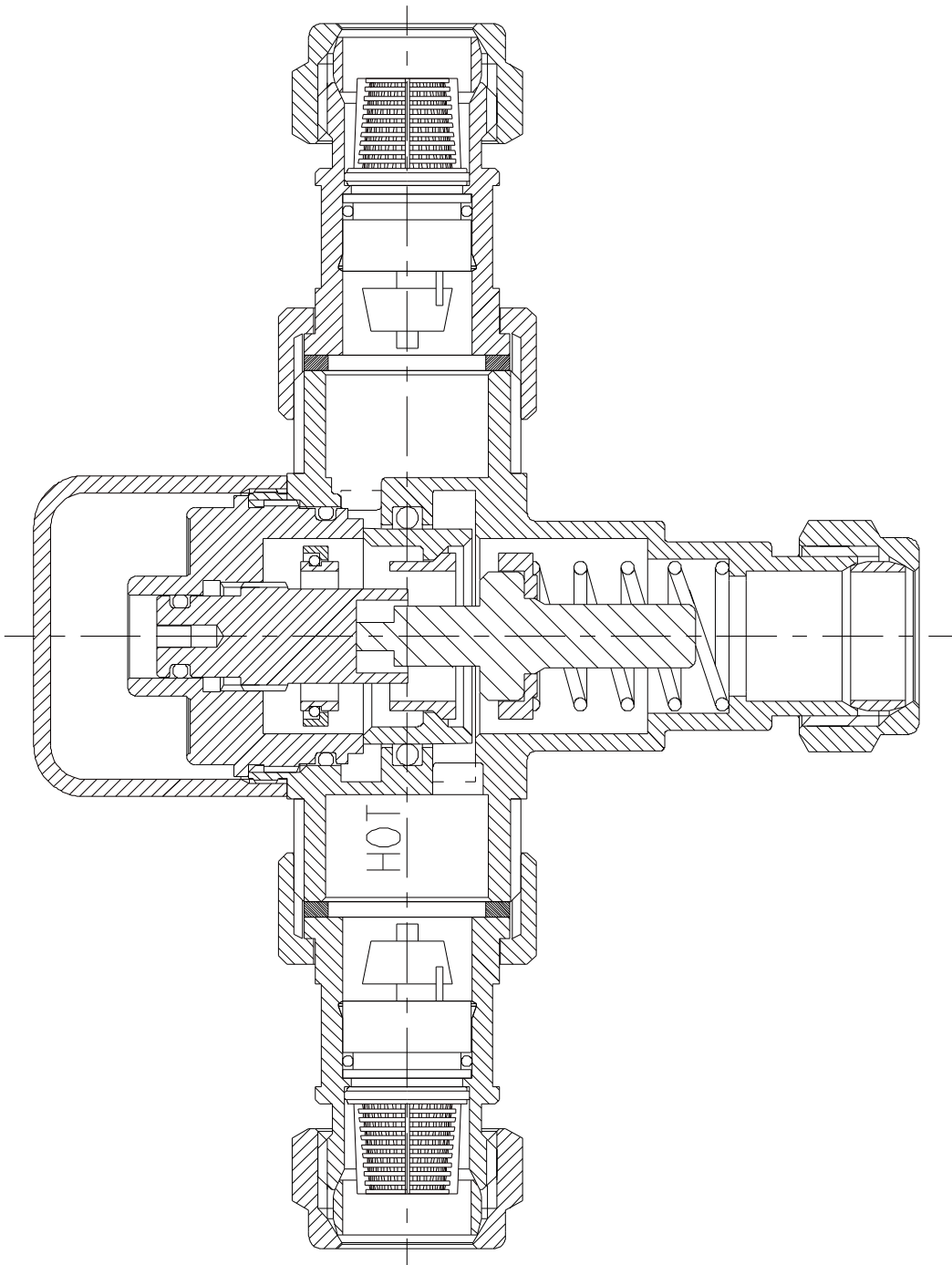

## CONDITIONS FOR NORMAL USE

In order to give compliance with N.H.S. specification Do8 and TMV2 scheme. The table below lists the conditions for normal use, the valves may perform adequately outside these parameters but the TMV2 and TMV3 scheme approval does not apply. If they are required to work with other supply conditions an engineer must carry out a risk assessment and satisfy themselves that the units are still suitable for use.

Table 1: Conditions for normal use

Operating pressure range	Low pressure	High pressure
Maximum static pressure - bar	10	10
Flow pressure, hot and cold - bar	0.2 to 1	1 to 5
Hot supply temperature - °C	52 - 65	52 - 65
Cold supply temperature - °C	5 to 20	5 to 20
Minimum Temperature Differential Between Mixed Temperature & Either Supply	10°C	10°C

## COMMISSIONING

Since the installed supply conditions may differ from those used in testing and setting the valves during final inspection and a valve may have several designations, it is necessary to reset the mix temperature. The following procedure should be used after ensuring:-

- The designation of the thermostatic mixing valve matches the intended application (i.e. if a shower is to be supplied at 2 bar then the valve must have a HP-S designation).
- The supply pressures match those for which the valve has been approved, see table 1 and valve details.
- The supply temperatures are such that they are within the permitted range (see table 1) and comply with guidance information on the prevention of legionella.

Note:- If the supply conditions are not within the parameters for normal use the valve may still be suitable, but individual engineers must carry out their own risk assessment and satisfy themselves that the units are still suitable for use.

Adjust the mixed water temperature in accordance with table 2, the method of adjustment is covered in the section temperature Setting.

Table 2: Mixed Water Temperature

Application	Abbreviated Designation	Mixed water temperature °C
Bidet	-HP-B, BE,-LP-B, BE	38 max
Shower	-HP-S,SE;-LP-S, SE	41 max
Washbasin	-HP-W,WE: -LP-W, WE	41 max
Bath (44°C fill)	-HP-T44;-LP-T44	44 max
Bath (46°C fill)	-HP-T46;-LP-T46	46 max

Note 1: For washbasins, washing under running water is assumed.

Note 2: Bath fill temperatures of more than 44°C should only be available when the bather is always under the supervision of a competent person (e.g. nurse or care assistant)

Note 3: A thermostatic mixing valve having multiple designations (i.e. it is capable of satisfying the requirements of this specification for more than one application) should be re-set on site to suit the designation required.

The following set of tests should be carried out.

- a) record the temperature of the hot and cold water supplies.
- b) record the temperature of the mixed water at the largest draw-off flow rate.
- c) record the temperature of the mixed water at a smaller draw-off flow rate, which shall be measured.
- d) isolate the cold water supply to the mixing valve and monitor the mixed water temperature.
- e) record the maximum temperature achieved as a result of (d) and the final temperature.
- f) record the equipment, thermometer etc. used for the measurements.

### **IN-SERVICE TESTING**

The purpose of in-service testing is to regularly monitor the thermal performance of the thermostatic mixing valve. Deterioration in performance can indicate the need for service work to be carried out on the system.

If the authority concerned does not have a planned test and maintenance schedule then the suggestions below should form the basis of a new system.

At intervals of 6 - 8 weeks and 12 - 15 weeks after commissioning:-

1. Check supply parameters are still within the expected values if not check system for faults.
2. Carry out commissioning procedures a) to c) using the same test equipment, if the mixed water temperature has changed a significant amount (by more than 1K) check to ensure in-line filters are clean, that the check valves are working and all isolating valves are fully open. If no fault can be found check and record the mixed water temperatures and re-adjust mixed water temperature to the values in table 2. Complete the commissioning procedure a) to f) if the mixed water temperature exceeds the values of the maximum recorded temperature by more than 2K the need for service work is indicated (see relevant instruction leaflet.)

Depending on the results of these two tests the following should be adopted

- a) If a small change (e.g. 1K to 2K) occurs in one of these tests or there is no significant change (e.g. 1K maximum) then the next in service test should be 24 to 28 weeks after commissioning.
- b) If small changes occur in both test or a larger change occurs in one test (exceeding 2K) then the next in service test should be carried out 18 to 21 weeks after commissioning.

These results can then be used to set a service interval which tests have shown can be used with no more than a small change in mixed water temperature. This method of determining service intervals is used to take into account various in-service conditions (i.e. water condition) that the valve may experience.

### **GENERAL ASSEMBLY AND SERVICING GUIDE**

1. Isolate hot and cold supplies. Remove Head Cover (9)
2. Unscrew Head (2) from Body (1).
3. Remove Adjusting screw (14) from Head (2) (N.B. Note approximate position of Adjusting screw (14) in Head (2) before removing. Replacement of Adjusting screw (14) in same position upon re-assembly ensures virtual restoration of original temperature).
4. Remove Thermostat (4), Piston assembly/Thermostat housing (3), Return spring (5).

### **TO CLEAN**

1. Soak all metal parts in de-scalent, wash off in clean water.
2. Lightly grease all metal parts with silicone grease.
3. Replace worn and damaged 'O'rings.

### **RE-ASSEMBLY**

1. Replace Return spring (5) and Piston assembly/Thermostat housing (3) and Thermostat (4).
2. Re-assemble Adjusting screw (14) to Head (2) to original setting.
3. Screw Head (2) into Body (1). Continue until it reaches a dead stop
4. Slight temperature adjustment may be necessary upon re-introduction of supply.

### **TEMPERATURE SETTING**

1. Turn Adjustment screw (14) clockwise for cooler temperature, anti-clockwise for warmer temperature. Replace Head Cover (9).

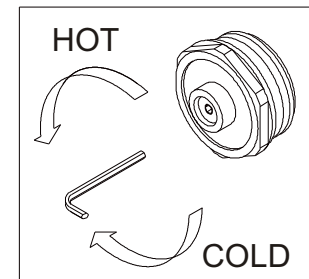

**NOTE :- ALL INSTALLATION AND MAINTENANCE PROCEDURES SHOULD BE CARRIED OUT IN ACCORDANCE WITH THESE GUIDELINES. PLEASE READ THESE GUIDELINES BEFORE COMMENCING ANY NEW INSTALLATION OR SERVICING OF EXISTING UNITS.**